

REV.	DESCRIPTION	DATE
A		02-2024

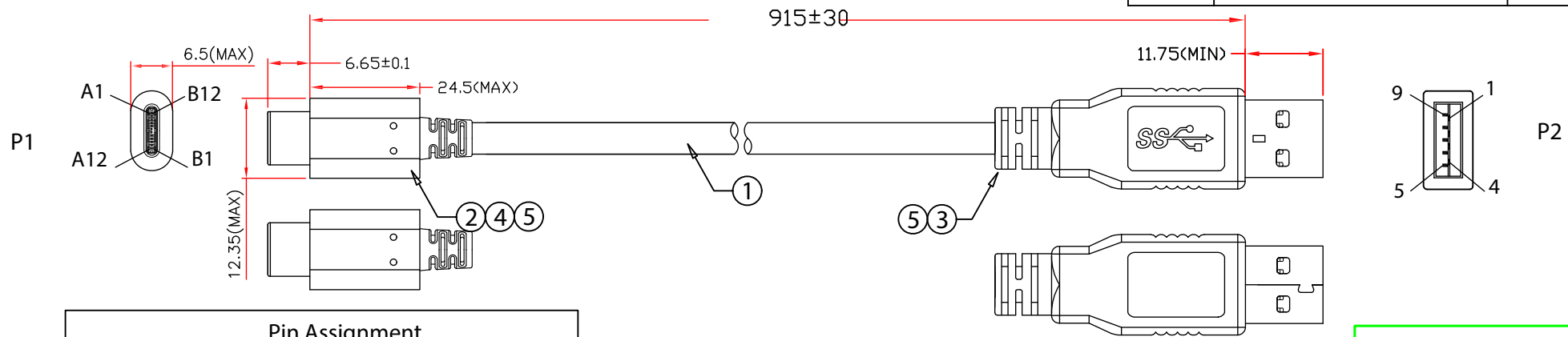

RoHS

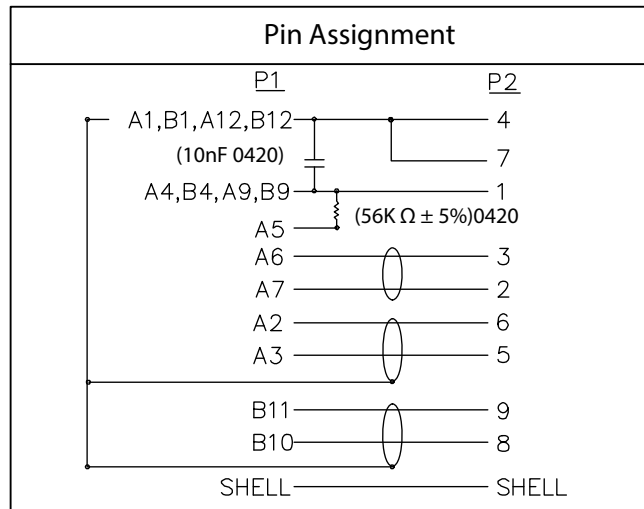

**NOTES:**

1. Electrical Test:
  - (1)100% Open Short & Miswire Test.
  - (2) Insulation Resistance: DC 300V ≥5MΩ
  - (3) Conductor Resistance: ≤2 Ω

PART NO.	CABLE LENGTH
10U3-32001	1 FT
10U3-32003	3 FT
10U3-32006	6 FT
10U3-32010	10 FT

5	Molded Black PVC Hood	ITEM NUMBER	10U3-320xx		DRAWER	JL
4	PE Matural	TITLE	USB3.0 Type A Male to Type C Male, 5Gb		CHECKED	
3	USB3.0 A Type Male ,Blue Insulation, Solder Type	MATERIAL	SCALE		APPROVED	
2	USB3.1 C Type Male ,Black Insulation, Solder Type, (56K Ω ± 5%)0420 + (10nF 0420)( Type C 3.0)	REV.	A	UNIT	MM	
1	USB3.1 Cable, UL2725 (1P*30#+D+AL+Mylar)*2+1P*32#+2C*24#+AL+B, OD: 4.2mm, Black Outer PVC Jacket	DRAWING NO:				
NO.	SPECIFICATIONS	ID(NO.)	44		 888-212-8295.com	
	BOM LIST					